

Catalogue de Pièces Compétition

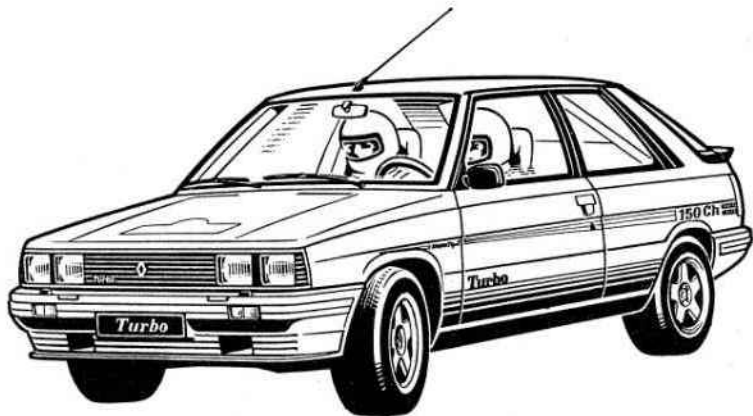

RENAULT 11 TURBO
Groupe A 150 ch

1	2	3	4	5	6	1985
7	8	9	10	11	12	

ANTONY Le: 16 Mai 1986

NOTE n° : 58

RISQUE DE SAUT DE LA COURROIE DE POMPE A EAU SUR
LES RENAULT 11 TURBO ET RENAULT 5 GT TURBO GROUPE A.

- Afin d'éviter l'échappement de la courroie de pompe à eau dans les conditions d'un régime moteur supérieur à 6000 tr/mm, après avoir mis en place la courroie, il est recommandé de monter la patte Rep A sur le couvercle de pompe à eau (utiliser pour sa fixation la vis du corps de pompe à eau Rep B).

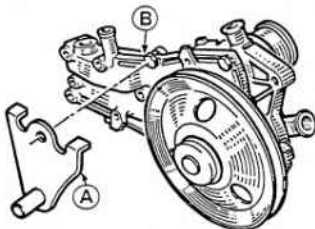

- L'élément Rep A est disponible au magasin pièces compétition à DIEPPE sous la Réf. 60 01 008 185.

N.B. La courroie, constituée de fibres synthétiques, ne doit pas être montée au tournevis.

ANTONY Le : 5 Août 1986

NOTE n° : 62

ALLUMAGE ELECTRONIQUE INTEGRAL BENDIX MONTE
SUR RENAULT 11 TURBO - GROUPE A

Ce boîtier est équipé d'un capteur de pression spécifique, plus performant.

1/ IDENTIFICATION :

Référence commerciale 77 11 066 953 disponible à DIEPPE.

(Réf. BENDIX sur l'étiquette collée sur le corps du boîtier AEI,
Voir ci-dessous :)

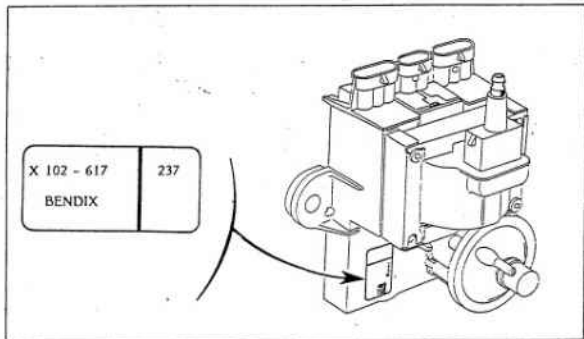

ANTONY Le: 6 Mai 1986

NOTE n° : 57

REGLAGE DU DISTRIBUTEUR D'ALLUMAGE MONTE
SUR RENAULT 11 TURBO GROUPE A

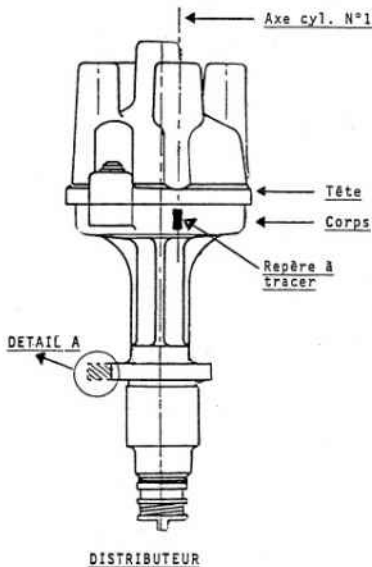

- Démontez le distributeur et repérez sur le corps de celui-ci l'axe cylindre N°1 (côté volant moteur) VOIR CI CONTRE
- Supprimer la partie hachurée afin de rendre le distributeur libre en rotation (voir Détail A)

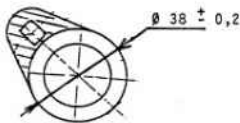

REGLAGE

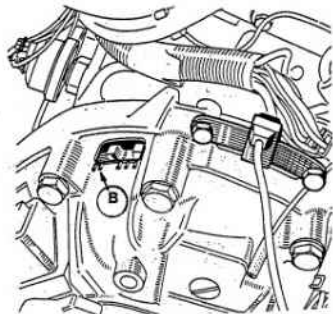

- Caler le moteur au point mort haut sur le 1^{er} cylindre, à l'aide du volant moteur et du repère B (Voir ci-contre) sur le carter de boîte.

- Remonter le distributeur.

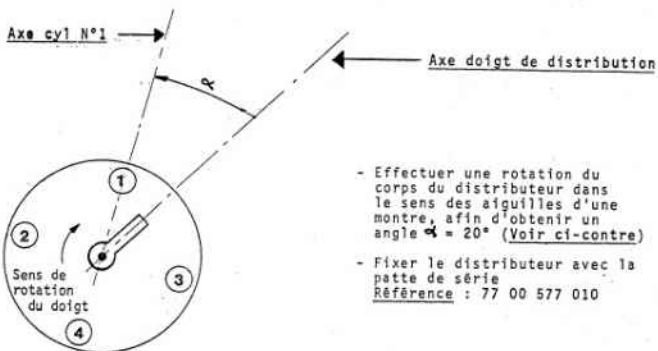

- Effectuer une rotation du corps du distributeur dans le sens des aiguilles d'une montre, afin d'obtenir un angle $\alpha = 20^\circ$ (Voir ci-contre)
- Fixer le distributeur avec la patte de série
Référence : 77 00 577 010

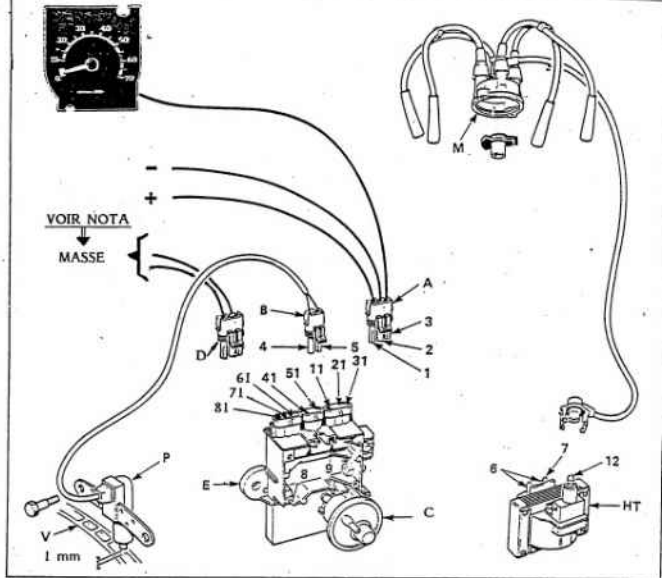

2/ BRANCHEMENT :

REPERE DESCRIPTION

A	1	+ Alimentation
	2	Masse
	3	Compte-tours
B	4	Bobinage capteur (blanc)
	5	Bobinage capteur (rouge)
	6	Borne + bobine et borne condensateurs anti-parasites
	7	Borne - bobine
	8	Contact + bobine
	9	Contact - bobine
	11	"Entrée" + module
	12	Plot secondaire
	21	Masse module
	31	Sortie compte-tours

REPERE DESCRIPTION

D	41	Information capteur
	51	Information capteur
	61	Non utilisé
	71	Entrée -4° d'avance
	81	Entrée +2° d'avance
	M	Tête de distributeur
	HT	Bobine haute tension
	C	Capsule à dépression
	E	Calculateur électronique ou module
	P	Capteur magnétique de position
	V	Volant

BRANCHEMENT (suite)

- NOTA :**
- 1/ Les bornes 8 et 11 sont reliées directement à l'intérieur du boîtier.
 - 2/ La mise à la masse de la borne 71 provoque le retrait de 4° d'avance sur toute la cartographie.
 - 3/ La mise à la masse de la borne 81 provoque l'addition de 2° d'avance sur toute la cartographie.
 - 4/ La mise à la masse des bornes 71 et 81 provoque le retrait de 2° d'avance sur toute la cartographie.

Pour réaliser le câblage du connecteur Rep. D (voir schéma page précédente), il faut utiliser les pièces ci dessous :

2 broches - Réf. 77 01 997 016

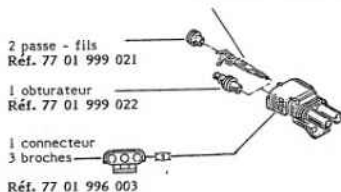

3/ CONTROLE DE LA LOI D'AVANCE

Il s'effectue moteur en marche en s'assurant que le boîtier AEI est correctement alimenté et le capteur est en bon état.

Le contrôle doit donner les valeurs d'avance suivantes :
(avec les bornes de l'AEI 71 et 81 non branchées)

LOI D'AVANCE RE 037	REGIME MOTEUR Tr/mn									TOLERANCES	
	900			3000			6000				
	Mini	Nominale	Maxi	Mini	Nominale	Maxi	Mini	Nominale	Maxi		
CAPSULE A PRESSION DEBRANCHEE	7°	≤ 9° ≤	13°	35°	≤ 37° ≤	38°	54°	≤ 57° ≤	60°	AVANCE EN DEGRES VOLANT	SUR REGIME ± 100 tr/mn
CAPSULE A PRESSION ALIMENTEE AVEC 900 MILLIBARS				13°	≤ 15° ≤	21°	31°	≤ 32° ≤	38°		SUR LA PRESSION ± 50 m bar

RENAULT
Spécial

RENAULT

Alpine

**Service
Compétition**

**Service
Compétition**

Clients

Pièces

RENAULT SPORT RALLYE
12, av. F. Sommer
92167 ANTONY Cédex
Téléphone : (1) 46 68 73 52
Télex : 20U941 F.

RENAULT ALPINE
Z.I. de Rouxmesnil Boutellies
76370 ROUXMESNIL BOUTEILLES
Téléphone : 35 82 93 14
35 82 33 65
Télex : 180426 F.

- ① 77 M 066 607 E = 1,5
- 60 00 008 053 E = 1,75
- ② 77 M 066 605
- ③ 77 M 066 606
- ④ 77 M 066 552
- ⑤ 77 M 066 604

Alvoage 76,6 mm
 R44 TURBO GLOUCE A.

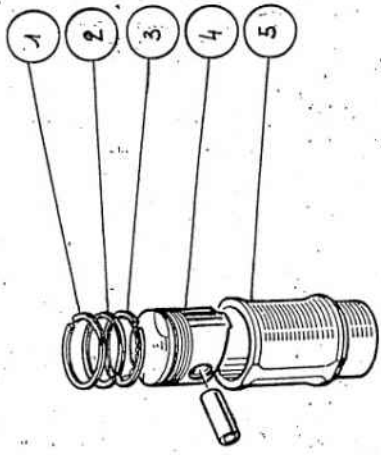

150 ch

- 1 - 77 11 066 759
- 2 - 77 11 066 760
- 3 - 77 00 588 916
- 4 - 77 11 066 773
- 5 - 77 11 066 182
- 6 - 77 00 639 647
- 7 - 77 11 066 761
- 8 - 77 11 066 778
- 9 - 77 11 066 775
- 10 - 77 11 066 777
- 11 - 77 11 066 856
- 13 - 77 11 066 776 (3/4" - 16 filets)
- 14 - 77 11 050 516
- 15 - 77 11 066 774
- 16 - 77 11 064 499
- 17 - 79 03 032 018
- 18 - 79 03 053 043
- 19 - 79 03 053 043
- 20 - 77 03 001 162
- 21 - 79 03 053 028
- 22 - 79 03 032 009
- 23 - 79 03 053 028
- 24 - 77 03 001 120
- 25 - 79 03 032 009
- 26 - 79 03 033 028
- 27 - 79 03 053 028
- 28 - 77 03 001 122
- 29 - 77 11 066 771
- 30 - 77 11 066 772

51 - 77 00556 453 - 3/4" / 3/4"
77 00325 923 - 3/4" / 170 x 150.

RENAULT 11 TURBO groupe A

10.78

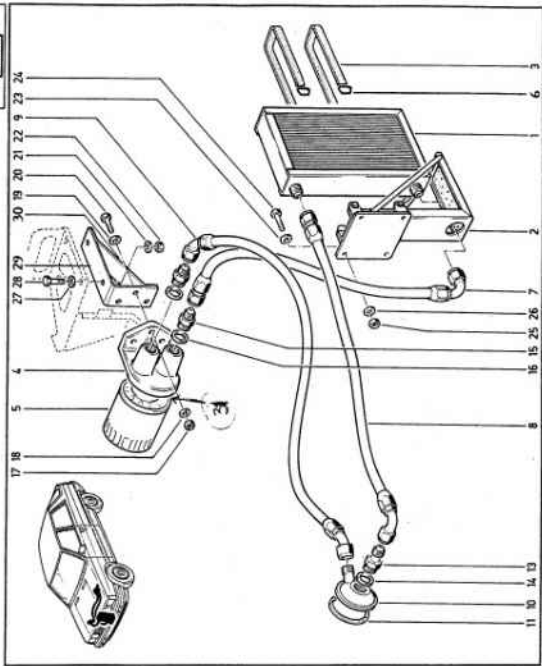

150 ch

- 1 - 77 11 066 641
- 2 - 77 00 644 703
- 3 - 60 01 000 149
- 4 - 77 11 066 643
- 5 - 77 11 066 642
- 6 - 77 03 062 025
- 7 - 77 03 062 025

RENAULT 11 TURBO groupe A

10.80

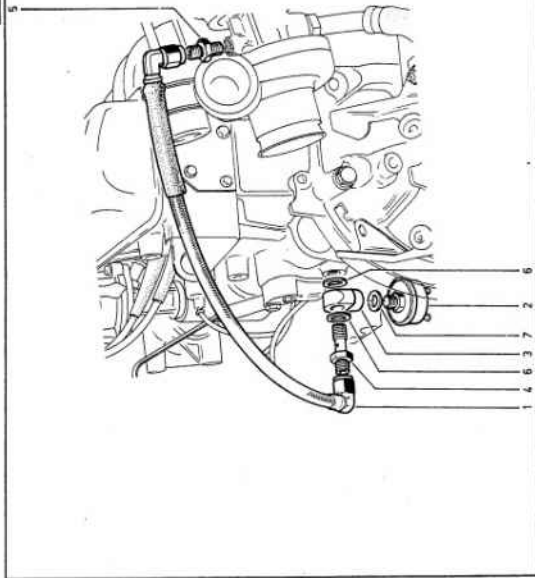

150 ch

I - 77 11 066 613

RENAULT 11 TURBO groupe A

11.40



150 ch

- 1 - 77 11 066 879
- 2 - 77 11 066 880
- 3 - 77 11 066 891
- 4 - 60 01 007 135

RENAULT 11 TURBO groupe A

12.02

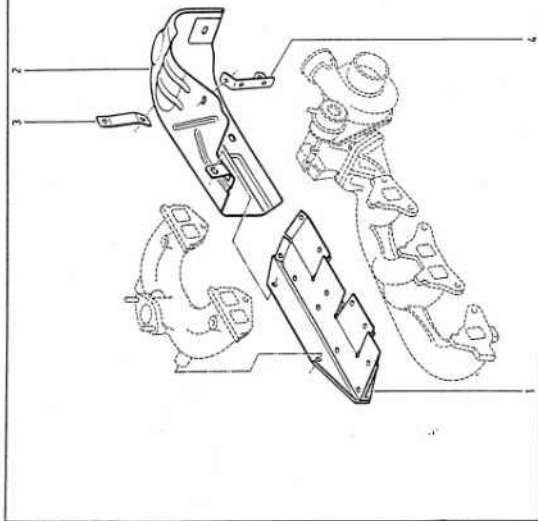



1320

RENAULT 11 TURBO groupe A

150 ch

- 1 - 60 01 004 968
- 2 - 77 11 066 864
- 3 - 77 11 066 596
- 4 - 77 11 066 597
- 5 - 60 01 005 981 (voir notice)
- 6 - 77 03 002 030
- 7 - 77 00 588 916
- 8 - 77 11 064 168 (Ø 70)
- 9 - 77 11 066 595
- 10 - 77 00 639 647

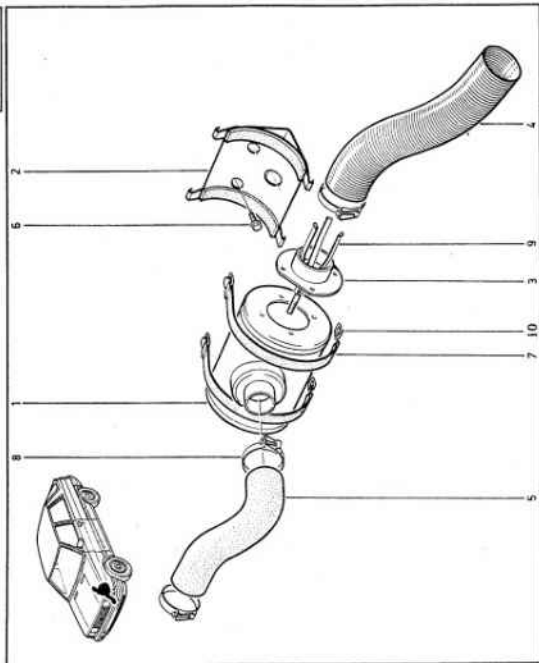

150 ch

1 - 77 11 066 577
2 - 77 11 066 872

RENAULT 11 TURBO groupe A

13.90

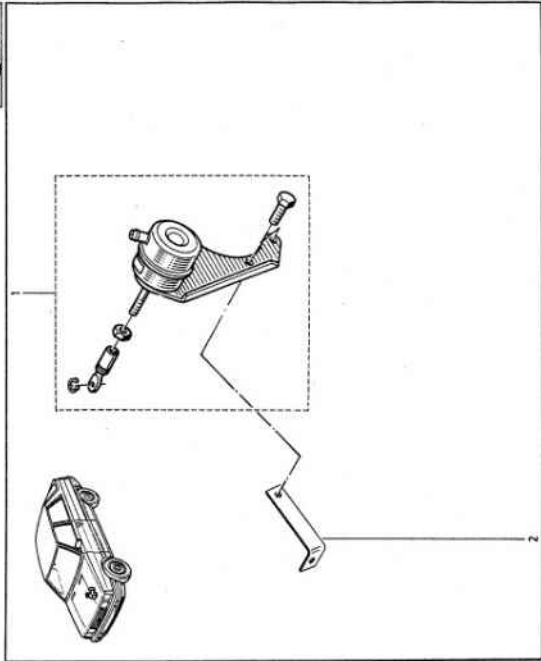

150 ch

1 - 77 11 066 756

2 - 77 11 066 756

RENAULT 11 TURBO groupe A

16.01



VENUFLEP N/A
LP M45



Valve.

A13 NT 737

Régulation exercé
par le clapet situé au
dessus de l'arbre.

(A venir fiche pour le
~~réglage~~
régulation)

est normal que le témoin
S'allume au ralenti



2

150 ch

1 - 77 11 066 953

RENAULT 11 TURBO groupe A

17.15



skewog.

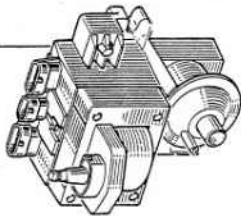

150 ch

1 - 77 01 366 084

17.20



RENAULT 11 TURBO groupe A



811
CLAMP

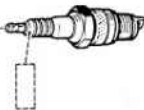

150 ch

- 1 - 77 11 066 680
- 2 - 77 11 066 871
- 3 - 77 00 635 419
- 4 - 77 11 066 677
- 5 - 77 00 756 428
- 6 - 77 11 066 866
- 7 - 77 00 687 550
- 8 - 77-00-758-428
- 9 - 77 03 001 114
- 10 - 77 03 037 031
- 11 - 79 03 032 006
- 12 - 77 01 013 271
- 13 - 77 00 586 307

RENAULT 11 TURBO groupe A

19.01

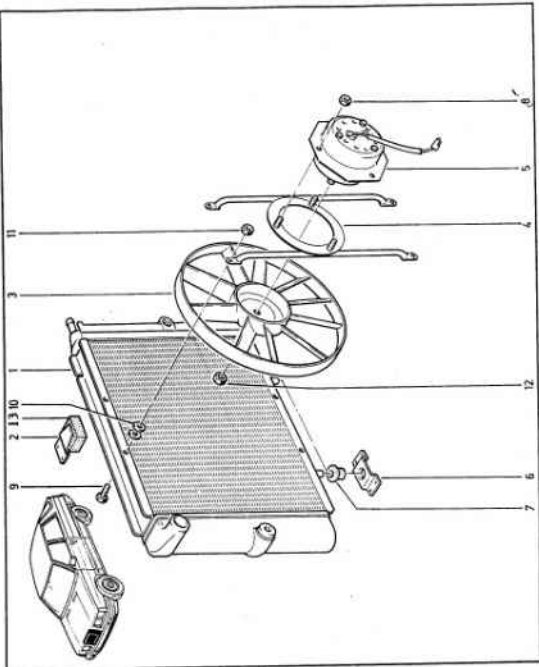

RENAULT 11 TURBO groupe A

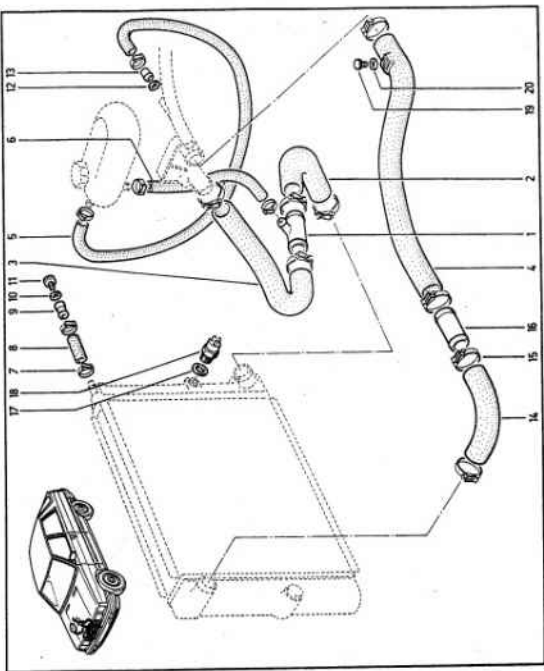

150 ch

1	- 77 11 066 833
2	- 77 11 066 834
3	- 77 11 066 832
4	- 77 11 066 829
5	- 77 11 066 836
6	- 77 11 066 835
7	- 77 01 400 358 (Ø = 14)
	- 77 01 400 359 (Ø = 20)
8	- 77 11 066 830
9	- 77 00 652 583
10	- 77 03 061 033
11	- 77 00 636 756
12	- 77 11 065 308
13	- 77 11 066 837
14	- 77 11 066 828
15	- 77 11 066 838 (Ø = 40)
	- 77 11 050 670 (Ø = 50)
	- 77 11 050 607 (Ø = 30)
16	- 77 11 066 831
17	- 77 00 268 560
18	- 77 11 065 158
19	- 77 00 518 589
20	- 77 03 061 007

150 ch

1 - 77 11 066 893

2 - 77 11 066 894

RENAULT 11 TURBO groupe A

19.03

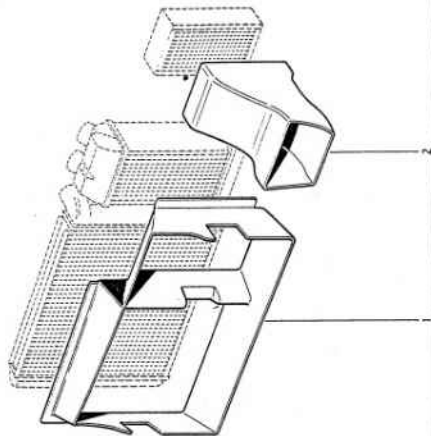

150 ch

- 1 - 77 11 066 566
- 2 - 77 11 066 868
- 3 - 77 11 066 638
- 4 - 77 11 066 637
- 5 - 77 11 066 867
- 6 - 77 00 687 550
- 7 - 77 11 064 168 (Ø 70)
- 8 - 77 11 066 888 (Lg : 210)
- 9 - 77 11 066 889 (Lg : 160)
- 10 - 77 11 066 890

RENAULT 11 TURBO groupe A

19.04
A 3/1/85

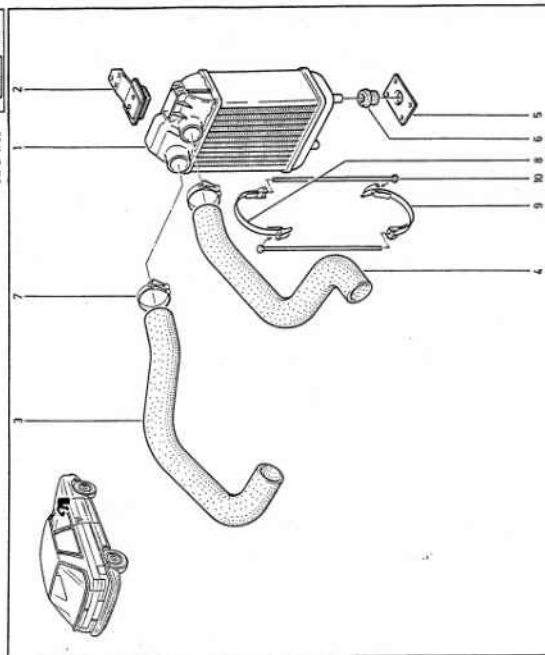

150 ch

- ① - 77 11 066 574
- ② - 77 11 066 573
- ③ - 77 11 066 571
- ④ - 77 11 066 570
- ⑤ - 77 11 066 569
- ⑥ - 77 03 001 693
- 7 - 77 03 037 014
- 8 - 77 03 001 693
- 9 - 79 03 032 018
- 10 - 77 03 001 162
- 11 - 79 03 032 018
- 12 - 77 11 066 572
- 13 - 77 00 686 449

RENAULT 11 TURBO groupe A

19.50

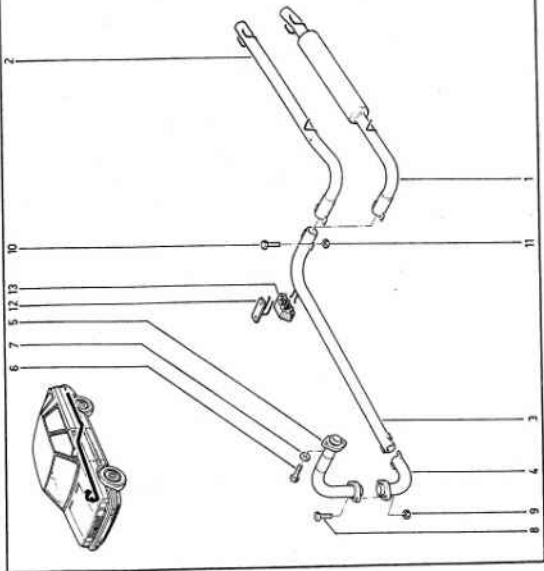

150 ch

- 1 - 77 11 065 510
- 2 - 77 11 065 511
- 3 - 77 11 065 509

RENAULT 11 TURBO groupe A

19.80

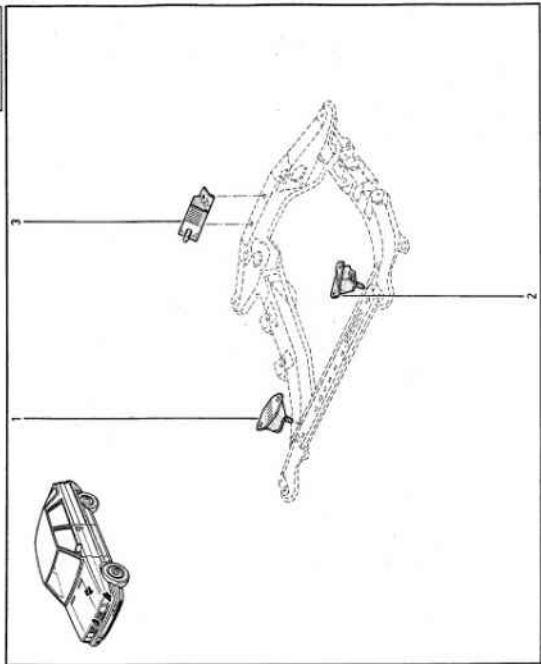

150 ch

- 1 - 77 11 065 984
- 2 - 77 11 066 644
- 3 - 77 11 066 758
- 4 - 77 11 066 645

RENAULT 11 TURBO groupe A

20.01

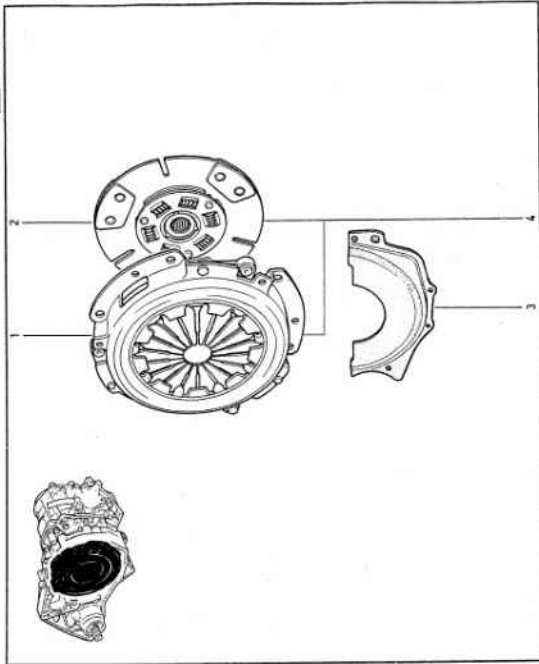

150 ch

- 1 - 77 11 066 662 (13 x 37)
- 77 11 066 663 (14 x 52)
- 2 - 77 11 066 652
- 3 - 77 11 066 653
- 4 - 77 11 066 654
- 5 - 77 11 066 657
- 6 - 77 11 066 651
- 7 - 77 11 066 661
- 8 - 77 11 066 649
- 9 - 77 11 066 655

RENAULT 11 TURBO groupe A

2147

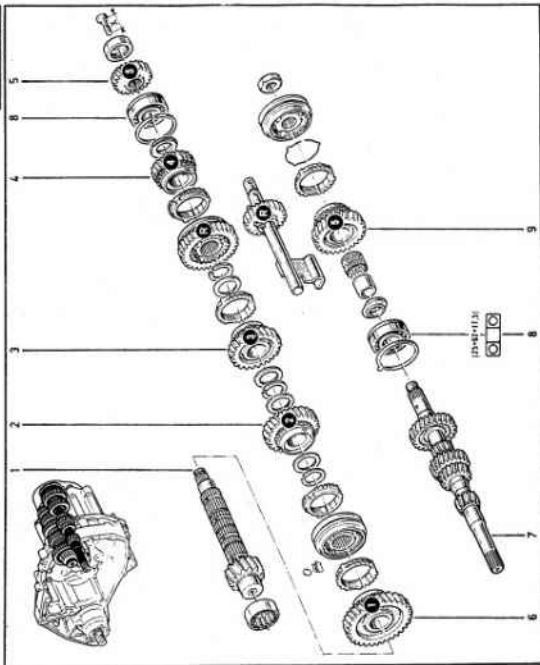

150 ch

- 1 - 77 11 066 664
- 2 - 77 11 066 658 (13 x 57)
- 3 - 77 11 066 659 (14 x 52)
- 4 - 77 00 664 915
- 5 - 77 11 066 873
- 6 - 77 00 611 935
- 7 - 77 00 717 385
- 8 - 77 03 061 105
- 9 - 77 11 066 650
- 10 - 77 11 066 665
- 11 - 77 11 066 668
- 12 - 77 00 717 386
- 12 - 77 03 067 059

RENAULT 11 TURBO groupe A

21.50

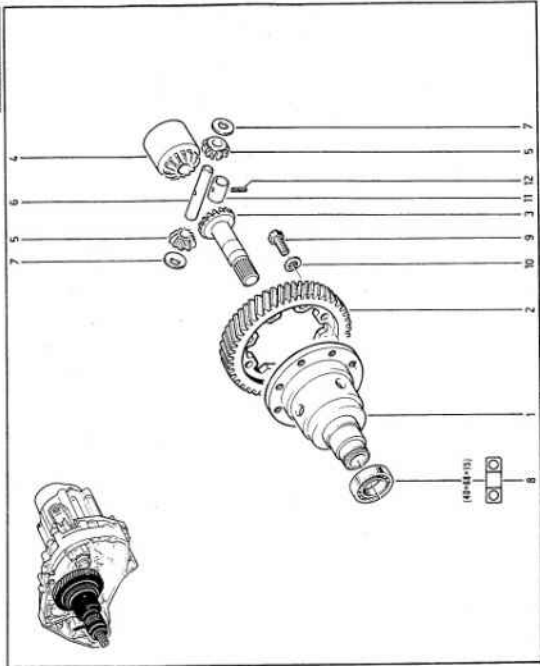



- 1 - 77 11 066 905
 2 - 77 11 066 915
 3 - 77 11 066 921
 4 - 77 11 066 906
 5 - 77 11 066 907
 6 - 77 11 066 908
 7 - 77 11 066 916
 8 - 77 11 066 909
 9 - 77 11 066 910
 10 - 77 11 066 914
 11 - 77 11 066 913
 12 - 77 11 066 911
 13 - 77 11 066 912
 14 - 77 11 066 917
 15 - 77 11 066 918
 16 - 77 11 066 919
 17 - 77 11 066 920
 18 - 77 11 066 658 (13x57)
 - 77 11 066 659 (19x52)

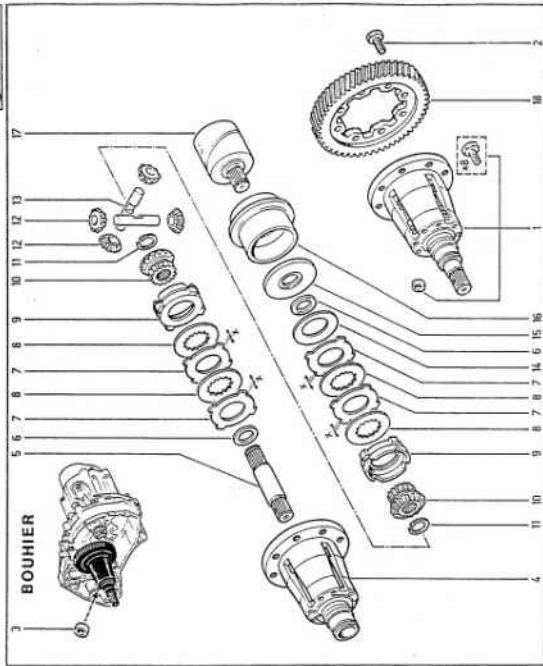

1	- 77 11 066 905
2	- 77 11 066 913
3	- 77 11 066 921
4	- 77 11 066 906
5	- 77 11 066 907
6	- 77 11 066 908
7	- 77 11 066 916
8	- 77 11 066 909
9	- 77 11 066 910
10	- 77 11 066 914
11	- 77 11 066 913
12	- 77 11 066 911
13	- 77 11 066 912
14	- 77 11 066 917
15	- 77 11 066 918
16	- 77 11 066 919
17	- 77 11 066 920
18	- 77 11 066 658 (13x57) - 77 11 066 659 (19x52)

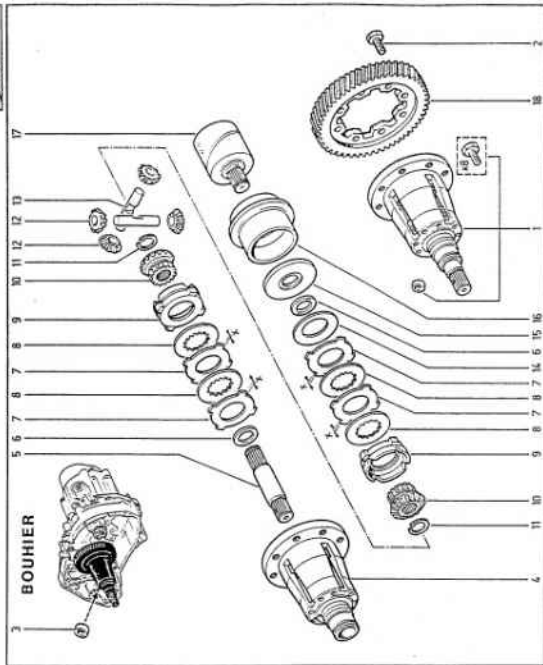

150 ch

RENAULT 11 TURBO groupe A

Montage avec
autobloquant
"BOUHIER"

- 1 - 77 01 349 741
- 2 - 77 01 463 766
- 3 - 77 01 463 955
- 4 - 77 00 531 733
- 5 - 77 03 066 007
- 6 - 77 01 366 100
- 7 - 77 01 463 194
- 8 - 79 03 067 016
- 9 - 77 03 067 207
- 10 - 77 01 201 233
- 11 - 77 01 348 568

29.00

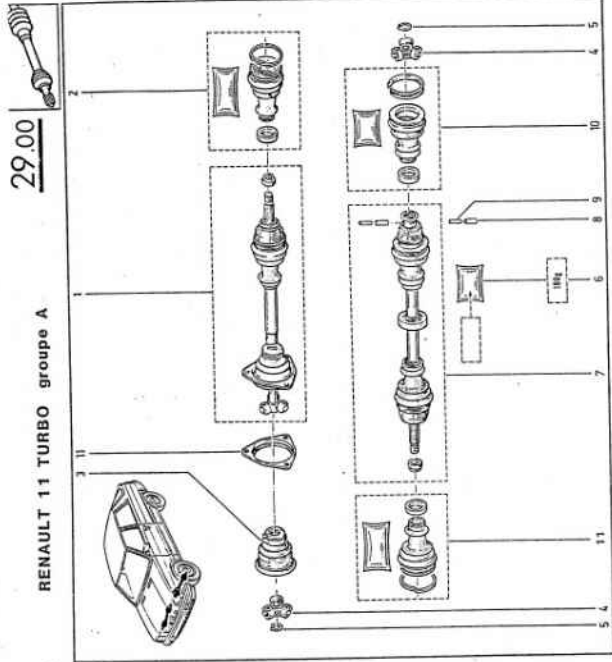

150 ch

RENAULT 11 TURBO groupe A

29.00



Montage avec
autobloquant
"BOUHER"

- 1 - 77 01 369 761
- 2 - 77 01 463 766
- 3 - 77 01 463 952
- 4 - 77 00 531 733
- 5 - 77 03 066 007
- 6 - 77 01 366 100
- 7 - 77 01 463 196
- 8 - 79 03 067 016
- 9 - 77 03 067 207
- 10 - 77 01 201 233
- 11 - 77 01 368 568

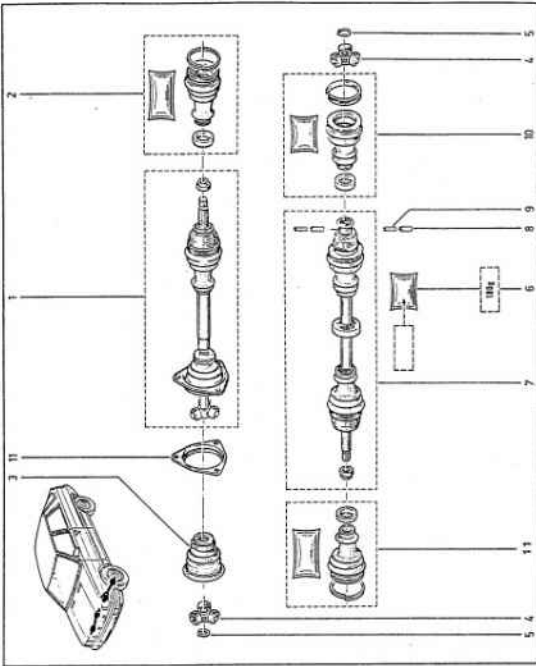

150 ch

1 - 77 11 066 736
2 - 77 03 038 047

RENAULT 11 TURBO groupe A

29.01
A 2M/3/BE

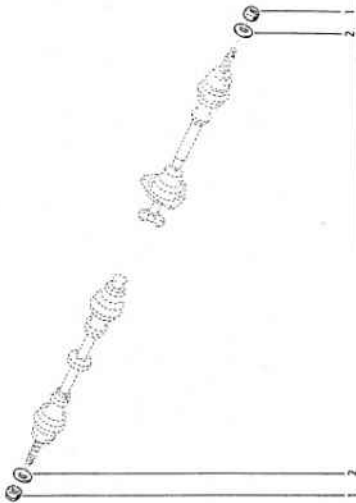

150 ch

- 1 - 77 11 065 399
- 2 - 77 11 065 400
- 3 - 77 11 065 248

RENAULT 11 TURBO groupe A

31.00

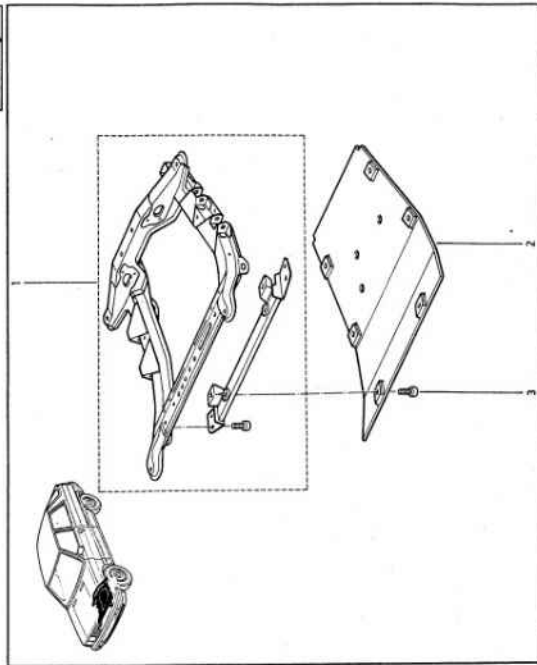



RENAULT 11 TURBO groupe A

150 ch

- 1 - 77 11 066 634 (sans rotule)
- 2 - 77 11 066 635 (sans rotule)
- 3 - 60 00 056 558
- 4 - 77 11 066 636
- 5 - 77 11 066 723
- 6 - 77 02 110 664 77 11 066 960
- 7 - 77 00 757 685 77 11 066 959
- 8 - 77 03 034 144 77 11 066 956 77 11 066 957
- 9 - 77 03 034 115
- 10 - 77 03 053 662

Renault turbo groupe 77 11 066 957
 1. dést 77 11 066 958

- 10 77 02 110 664 plateau
- 77 02 158 663 0.10mm
- 77 11 066 960 0.11mm

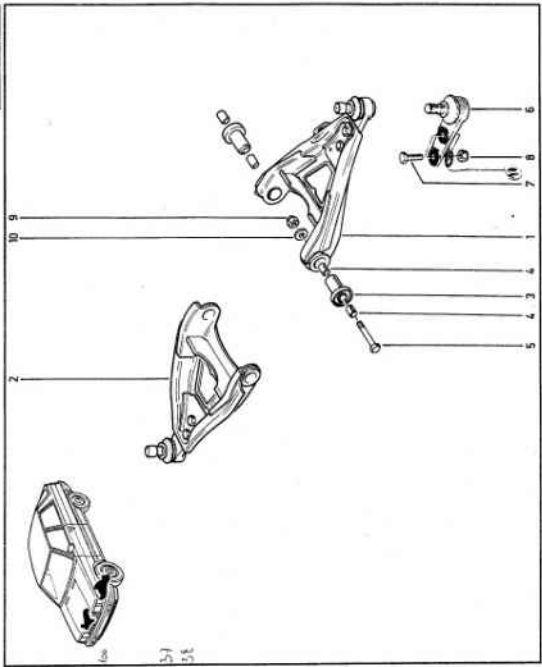

nouveau plat 0.11mm



31.40

RENAULT 11 TURBO groupe A

150 ch

- 1 - 77 11 066 720
- 2 - 77 11 066 721
- 3 - 77 11 066 627
- 4 - 77 11 066 628
- 5 - 77 11 066 722
- 6 - 77 11 066 592
- 7 - 77 00 677 758
- 8 - 77 00 677 029
- 9 - 77 00 677 029
- 10 - 77 11 066 859

3200761 606
 origine 275 Faurip
 Duple - Gendat - 77 00 5514 534

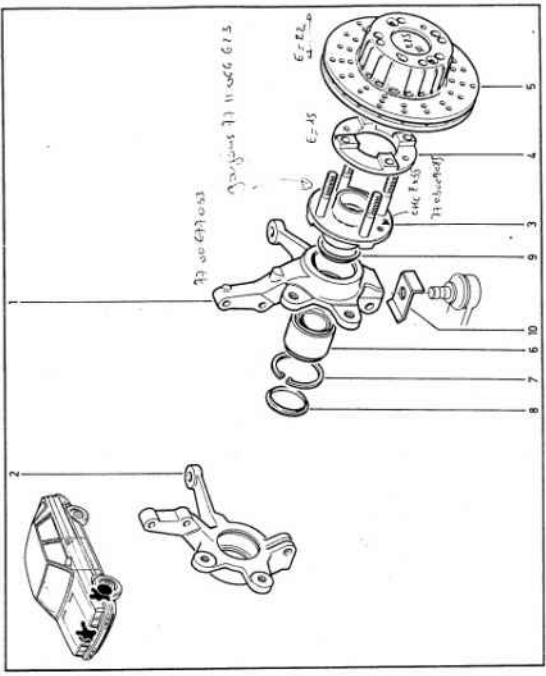

150 ch

- 1 - 77 11 066 715
- 2 - 77 11 066 716
- 3 - 77 11 066 718
- 4 - 77 11 066 719
- 5 - 77 11 066 717
- 6 - 77 01 020 243
- 7 - 77 11 066 877 (592)

© 1985 Renault S.A. - 43, Avenue

RENAULT 11 TURBO groupe A

31.41

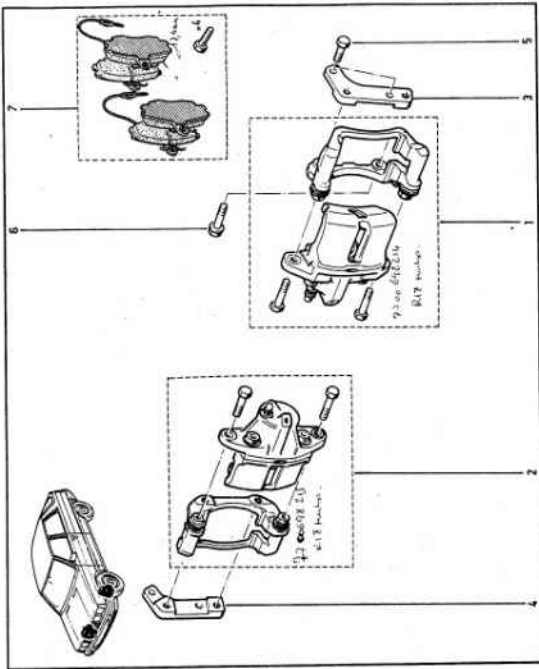

150 ch

- 1 - 77 00 760 452 (x = 23)
- 2 - 77 00 762 573 (Ø 23)
- 3 - 77 00 760 264 (Ø 23)

RENAULT 11 TURBO groupe A

32.10

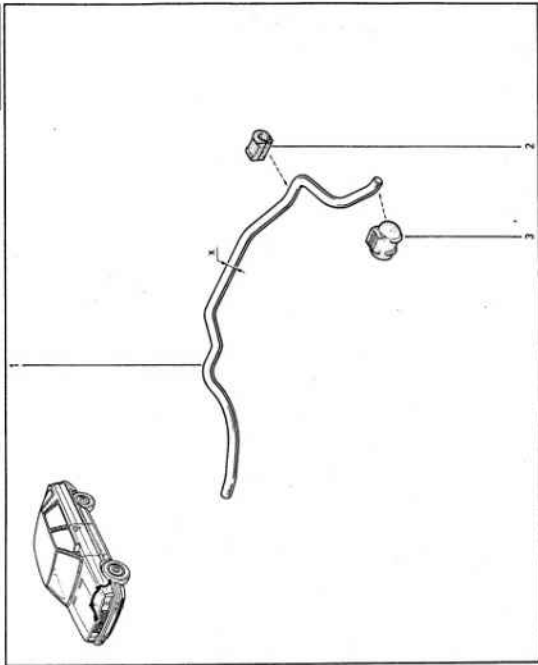

150 ch

- 1 - 77 11 066 528 + 77 11 066 201X
- 2 - 77 11 066 724
- 3 - 77 11 066 730
- 4 - 77 11 066 731
- 5 - 77 11 066 732
- 6 - 77 11 066 733 33 11 066 914X
- 7 - 77 11 066 734
- 8 - 77 11 066 735 33 11 066 914X
- 9 - 77 11 066 740 (BLANC) 77 11 066 873 (Blau)
- 10 - 77 11 066 741 (BLANC) 77 11 066 874 (Blau)
- 11 - 77 04 001 257
- 12 - 77 00 760 571
- 13 - 77 03 053 452
- 14 - 77 03 034 096
- 15 - 77 03 053 662
- 16 - 77 03 034 115
- 17 - 77 11 066 858

Contacto. 77 11 067 000

RENAULT 11 TURBO groupe A

32.01

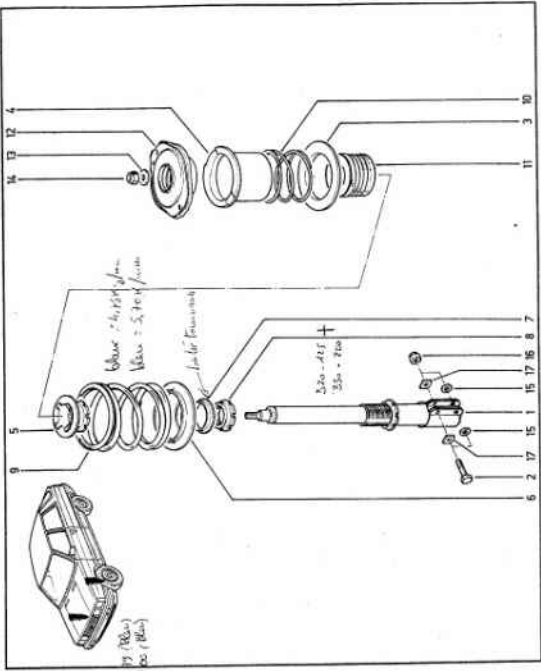

150 ch

- 1 - 77 00 765 337
- 2 - 77 00 765 338
- 3 - 77 11 066 614
- 4 - 77 11 066 615

RENAULT 11 TURBO groupe A

33.01

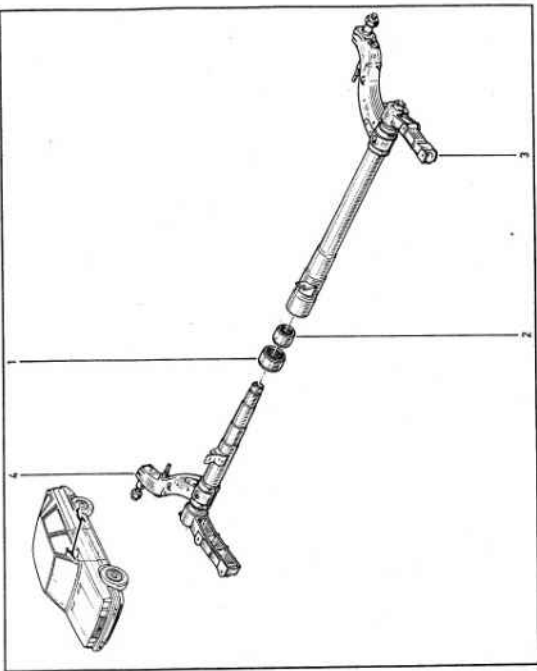

150 ch

- 1 - 77 00 771 157 (Ø 26)
- 2 - 77 00 771 156 (Ø 26)
- 3 - 77 11 066 824 (Ø 16)
- 4 - 77 11 066 823 (Ø 16)

RENAULT 11 TURBO groupe A

33.61

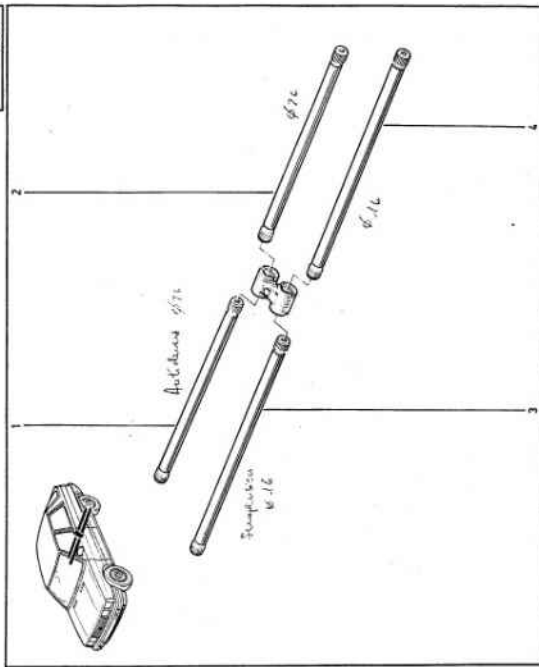

150 ch

- 1 - 77 11 066 821 (Ø 15,5)
- 1 - 77 00 759 871 (Ø 18,5)
- 2 - 77 11 066 822 (Ø 15,5)
- 2 - 77 00 759 870 (Ø 18,5)

RENAULT 11 TURBO groupe A

33.60

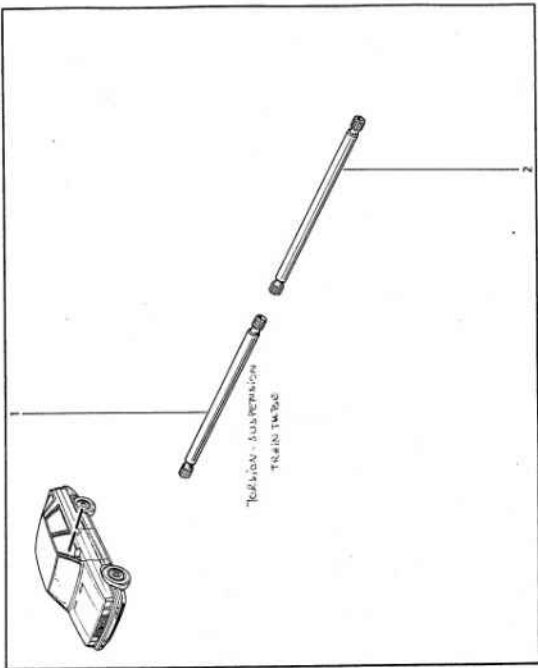

150 ch

- 1 - 77 11 066 901 (train tube)
- 2 - 77 11 066 902 (Train 4 barres)
- 3 - 77 11 066 742
- 4 - 77 11 066 743 Ep : 5
- 5 - 77 11 066 745 Ep : 20
- 6 - 77 11 066 744 Ep : 10
- 7 - 77 11 066 746
- 8 - 77 11 066 747
- 9 - 77 11 066 814
- 10 - 77 00 557 856
- 11 - 77 05 001 153
- 12 - 77 00 558 160
- 13 - 77 00 557 850
- 14 - 77 03 036 093
- 15 - 77 03 053 495
- 15 - 77 11 066 875

RENAULT 11 TURBO groupe A

34.01
A 24/2/86

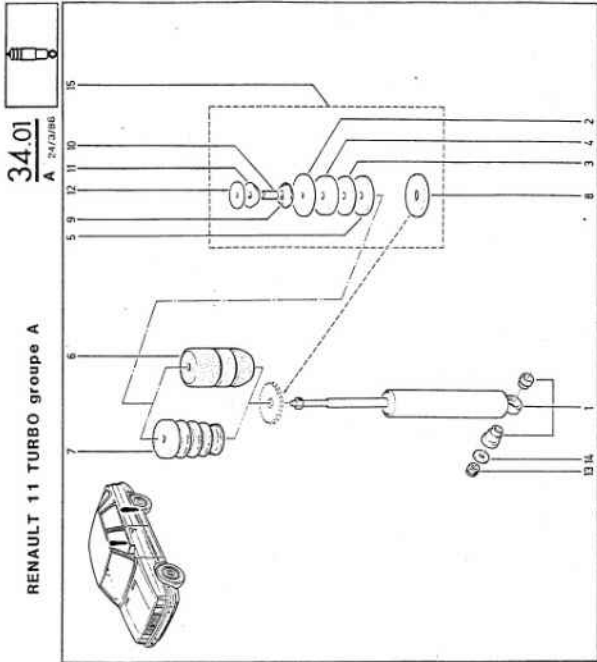

150 ch

1 - 77 00 734 787 (X=25)
77 11 066 993 (X=27)

RENAULT 11 TURBO groupe A

34.10

A 26/3/86



150 ch

- 1 - 77 01 202 142
- 2 - 77 01 202 143
- 3 - 77 01 030 437
- 4 - 77 01 030 438
- 5 - 77 01 025 057
- 6 - 77 00 656 379
- 7 - 77 11 086 517 (592)

8 - 77 00 776 103
9 - 77 00 776 102

RENAULT 11 TURBO groupe A

34.35

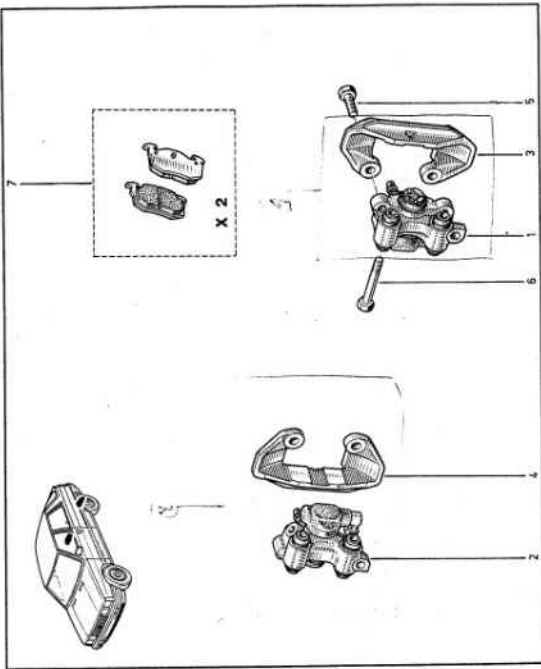

150 ch

I - 77 11 065 850

RENAULT 11 TURBO groupe A

35.01

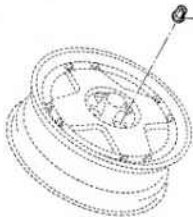

150 ch

RENAULT 11 TURBO groupe A

37.01
A 11.2.86



- 1 - 77 11 066 796
- 2 - 77 11 066 798
- 3 - 77 11 066 801
- 4 - 77 11 066 804
- 5 - 77 03 053 662
- 6 - 77 03 050 085
- 7 - 79 03 032 072
- 8 -
- 9 - 77 11 066 803
- 10 - 79 03 032 072
- 11 - 77 11 066 802
- 12 - 79 03 053 085
- 13 - 77 03 068 002

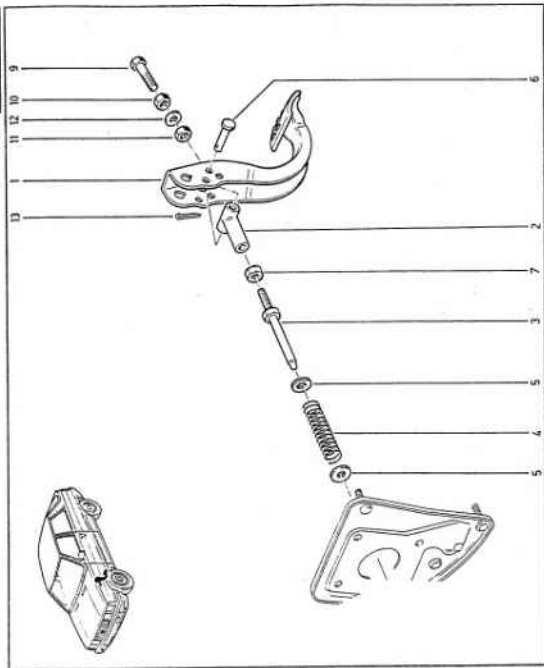

150 ch

- 1 - 77 11 066 796 (9^m)
- 2 - 77 11 066 904
- 3 - 77 00 616 986
- 4 - 79 03 057 003
- 5 - 79 03 032 012
- 6 - 77 00 573 753 (1m)
- 7 - 77 00 701 608
- 8 - 77 03 063 002
- 9 - 77 11 066 802
- 10 - 79 03 053 095
- 11 - 79 03 032 072
- 12 - 77 11 066 803
- 13 - 77 03 050 085
- 14 - 77 03 039 037
- 15 - 79 03 053 093

RENAULT 11 TURBO groupe A

37.60

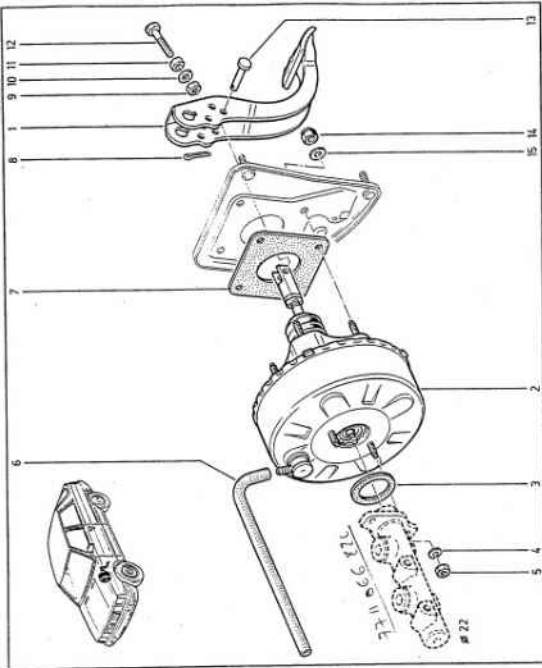

150 ch

- 1 - 50 00 388 495
- 2 - 77 11 066 851
- 3 - 50 00 388 114
- 4 - 50 00 389 763
- 5 - 77 11 066 848
- 6 - 77 11 066 847
- 7 - 77 11 066 844
- 8 - 50 00 390 234
- 9 - 77 11 066 841
- 10 - 77 04 003 764
- 11 - 77 00 705 561 (Arrière)
- 77 00 560 788 (Avant)
- 12 - 77 11 066 840
- 13 - 77 11 066 842
- 14 - 77 04 003 764
- 15 - 77 11 066 843
- 16 - 50 00 388 495
- 17 - 77 11 066 852
- 18 - 50 00 389 800
- 19 - 79 03 062 005
- 20 - 07 05 961 100
- 21 - 77 11 066 854
- 22 - 77 11 066 853
- 23 - 77 11 066 850
- 24 - 77 11 066 849
- 25 - 77 11 065 266
- 26 - 77 11 065 532
- 27 - 77 11 066 825

Επιπλέον: Π 150 V 420
 Επιπλέον: Π 13 X 100

RENAULT 11 TURBO groupe A

37.80

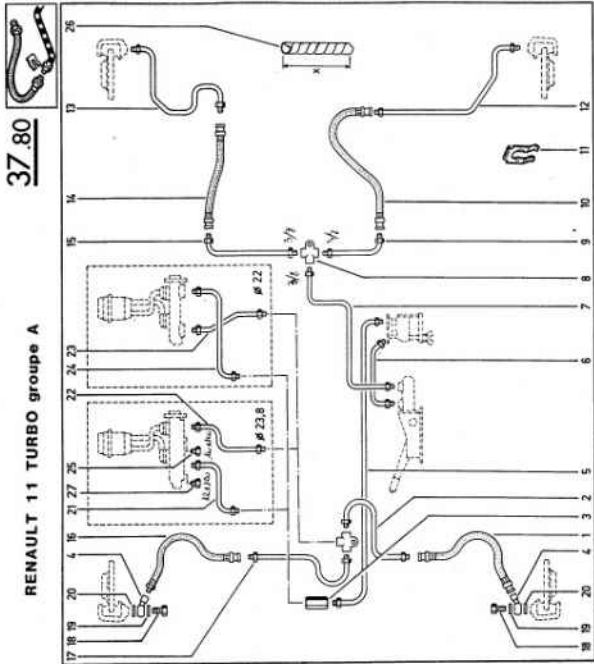

150 ch

RENAULT 11 TURBO groupe A

37.81

- 1 - 50 00 358 495
- 2 - 77 11 066 851
- 3 - 50 00 358 116
- 4 - 50 00 359 763
- 5 - 77 11 066 848
- 6 - 77 11 066 847
- 7 - 77 11 066 844
- 8 - 50 00 390 234
- 9 - 77 11 066 841
- 10 - 77 06 003 766
- 11 - 77 06 705 561 (Arrière)
- 11 - 77 06 760 788 (Avant)
- 12 - 77 11 066 840
- 13 - 77 11 066 842
- 14 - 77 06 003 766
- 15 - 77 11 066 843
- 16 - 50 00 358 495
- 17 - 77 11 066 852
- 18 - 50 00 389 800
- 19 - 79 03 062 005
- 20 - 07 05 961 100
- 21 - 77 11 066 841
- 22 - 77 11 066 849
- 23 - 77 11 065 532

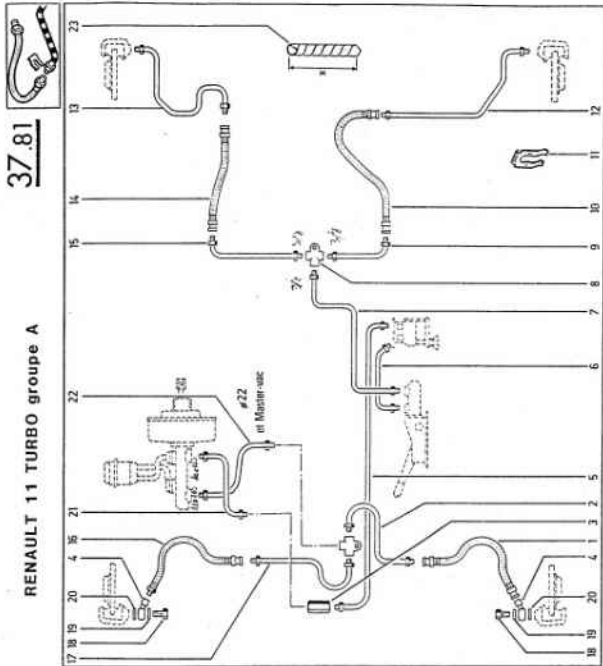

150 ch

1	-	77	11	066	782	(5/8 ¹¹)
2	-	77	11	066	787	
3	-	77	11	066	811	
4	-	77	11	066	812	
5	-	77	11	066	783	
6	-	77	11	066	791	
7	-	77	11	066	855	
8	-	77	00	662	771	
9	-	77	00	662	770	
10	-	77	11	066	788	
11	-	77	03	066	150	
12	-	77	03	050	033	
13	-	77	00	662	784	
14	-	77	11	066	793	
15	-	77	03	066	151	
16	-	77	11	066	792	
17	-	77	03	066	162	
18	-	77	11	066	885	
19	-	77	03	053	074	
20	-	77	03	001	236	
21	-	77	11	066	810	
22	-	77	11	066	806	
23	-	77	03	053	172	
24	-	79	03	057	005	
25	-	79	03	032	018	
26	-	79	03	032	072	
27	-	60	00	002	035	
28	-	60	00	002	036	
29	-	77	11	066	846	
30	-	77	00	662	742	
31	-	77	00	662	741	
32	-	77	00	662	781	
33	-	77	11	066	794	
34	-	77	11	065	266	
35	-	77	11	066	825	

RENAULT 11 TURBO groupe A

38.01

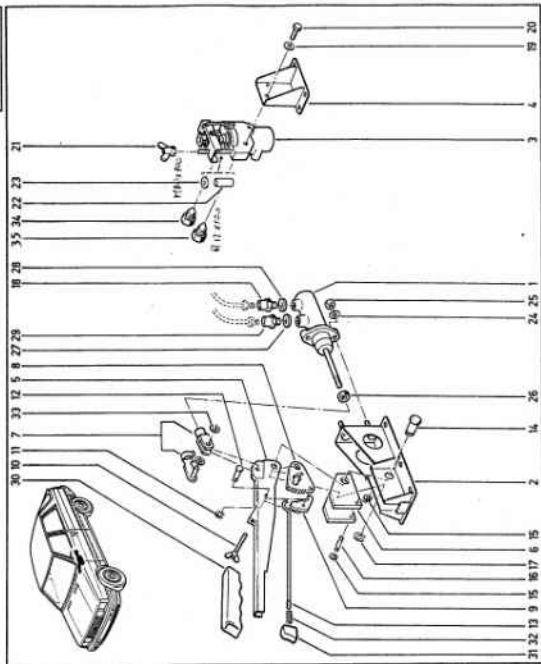

150 ch

- 1 - 77 11 065 991
- 2 - 77 11 065 402
- 3 - 77 03 001 241
- 4 - 79 03 053 043

RENAULT 11 TURBO groupe A

40.01

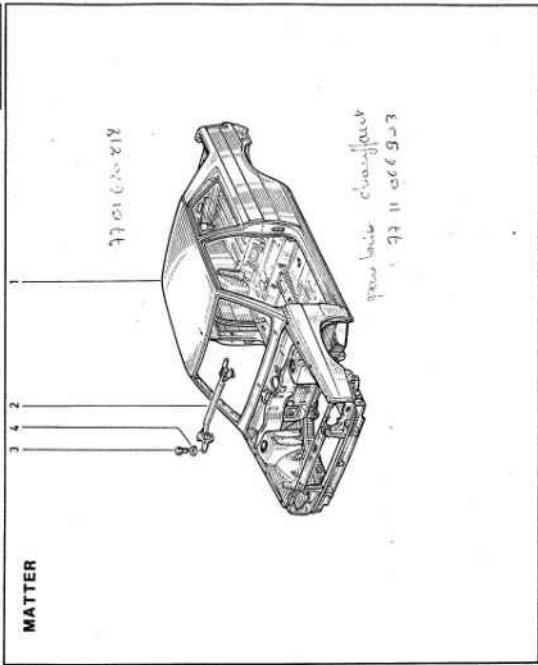

150 ch

- 1 - 77 11 065 401T
- 77 11 066 952
- 2 - 77 03 001 162

RENAULT 11 TURBO groupe A

46.10

A 26/3/86

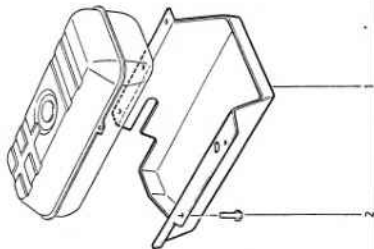

150 ch

- 1 - 77 11 065 775
- 2 - 77 11 066 768 (C)
- 77 11 066 769 (D)
- 3 - 77 11 066 767
- 4 - 77 03 001 904
- 5 - 79 03 053 028
- 6 - 77 11 066 766

RENAULT 11 TURBO groupe A

48.01

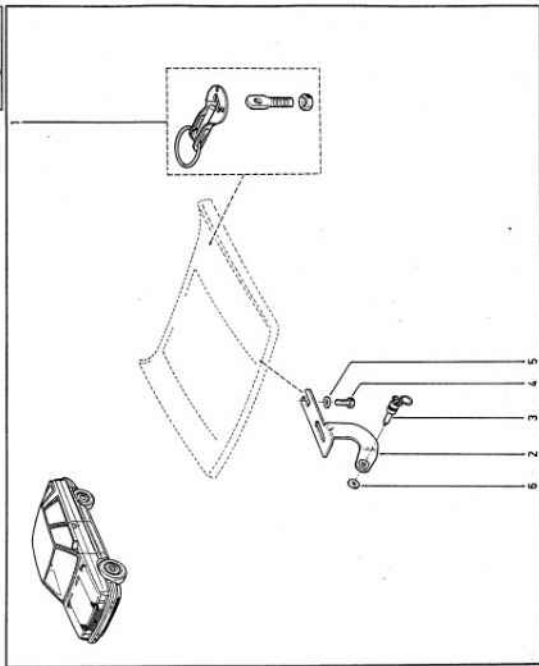

150 ch

I - 77 11 066 903

RENAULT 11 TURBO groupe A

54.00

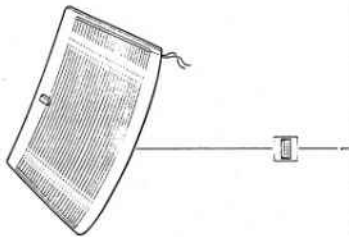

150 ch

- 1 - 77 11 066 666
- 2 - 77 11 066 762

RENAULT 11 TURBO groupe A

55.25

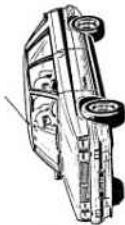

2

GRUPE A
RENAULT *SPORT*

COULEUR : JAUNE ET NOIR SUR FOND BLANC

GRUPE N
MONTE CARLO

GRUPE N
MONTE CARLO

GRUPE N
RENAULT *SPORT*



150 ch

1 - 77 11 066 600

2 - 77 01 201 798

3 - 77 11 065 476 (GAUCHE)

- 77 11 065 512 (DROIT)

RENAULT 11 TURBO groupe A

77.11

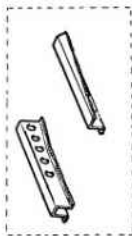
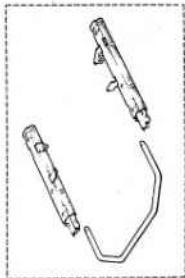
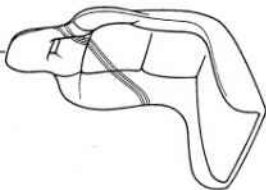

150 ch

1 - 77 11 065 553
- 77 11 065 398 (6 POINTS)

RENAULT 11 TURBO groupe A

81.00



MATTER

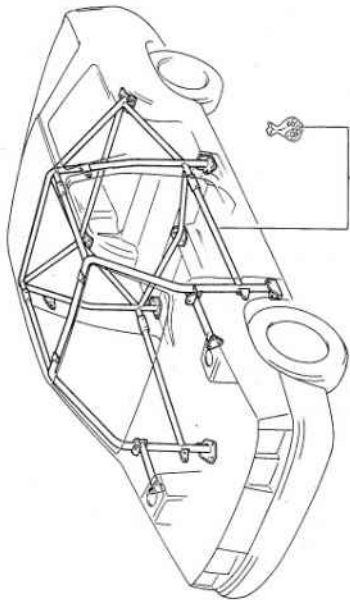

150 ch

I - 77 11 066 882 Multi Point
- 77 11 066 881 (6 points)

RENAULT 11 TURBO groupe A

81.10



DEVIL

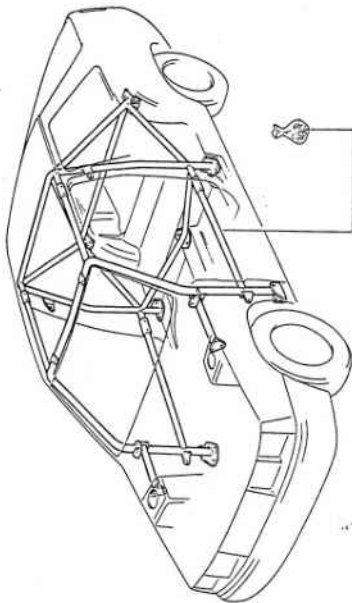

150 ch

- 1 - 77 11 066 876
- 2 - 77 03 083 037

RENAULT 11 TURBO groupe A

83.01

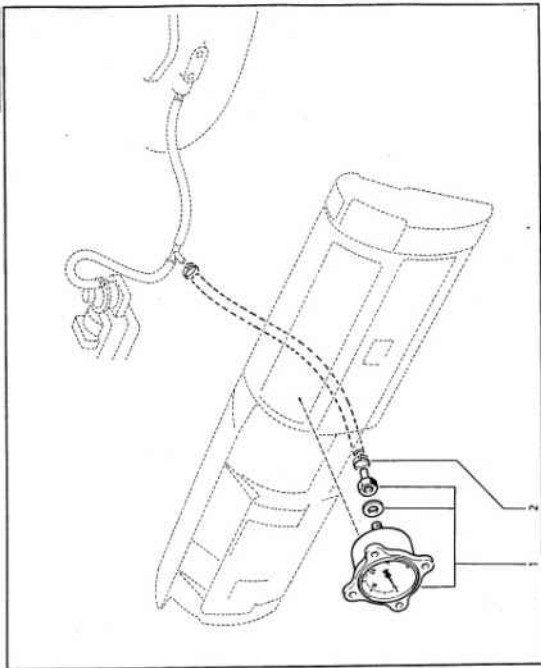

150 ch

I - 77 11 066 757

RENAULT 11 TURBO groupe A

85.23



STEUERARM
535 36 802



150 ch

- 1 - 77 11 066 748
- 2 - 77 11 066 749
- 3 - 60 01 003 561
- 4 - 77 11 065 835
- 5 - 77 11 064 372
- 6 - 77 11 064 374
- 7 - 77 11 063 372
- 8 - 60 01 009 036
- 9 - 79 02 037 013
- 10 - 60 01 009 036
- 11 - 79 02 037 013

RENAULT 11 TURBO groupe A

90.01

